

1.25Gbps Single Mode WDM SFP 36dB Transceiver

Features

- CWDM DFB Laser diode transmitter
- InGaAs PIN photodiode receiver
- Meet SFP MSA and SFF-8472 with single SC receptacle
- Digital Diagnostic Monitoring
- Hot-pluggable
- 36dB Power Budget at Least

Application

- a. ATM
- b. SONET/SDH
- c. Gigabit Ethernet

General

SFP-WDM51.36, SFP-WDM57.36 is small form factor pluggable module for Gigabit Ethernet 1000BASE-BX and Fiber Channel single fiber communications by using 1510nm/1570nm transmitter and 1570nm/1510nm receiver. It is with the SFP 20-pin connector to allow hot plug capability.

The transmitter section uses a multiple quantum well laser and is a class 1 laser compliant according to International Safety Standard IEC 60825. The receiver section uses an integrated detector preamplifier (IDP) mounted in an optical header and a limiting post-amplifier IC

Absolute Maximum Ratings

Parameter	Symbol	Min.	Max.	Unit
Storage Temperature	T_s	-40	+85	°C
Supply Voltage	V_{CC}	-0.5	3.6	V
Operating Relative Humidity		-	95	%

*Exceeding any one of these values may destroy the device immediately.

Recommended Operating Conditions

Parameter	Symbol	Min.	Typical	Max.	Unit
Operating Case Temperature	T_A	-5		+70	°C
Power Supply Voltage	V_{CC}	3.15	3.3	3.45	V
Power Supply Current	I_{CC}			300	mA
Data Rate	FC		1.063		Gbps
	GBE		1.25		Gbps

Performance Specifications - Electrical

Parameter	Symbol	Min.	Typ.	Max	Unit	Notes
Transmitter						
LVPECL Inputs(Differential)	Vin	400		2000	mVpp	AC coupled inputs ^{*(note1)}
Input Impedance (Differential)	Zin	85	100	115	ohm	Rin > 100 kohm @ DC
TX_Dis	Disable	2		Vcc	V	
	Enable	0		0.8		
TX_FAULT	Fault	2		Vcc+0.3	V	
	Normal	0		0.5		
Receiver						
LVPECL Outputs (Differential)	Vout	370		2000	mVpp	AC coupled outputs ^{*(note1)}
Output Impedance (Differential)	Zout	85	100	115	ohm	
RX_LOS	LOS	2		Vcc+0.3	V	
	Normal	0		0.8	V	
MOD_DEF (0:2)	VoH	2.5			V	With Serial ID
	VoL	0		0.5	V	

Performance Specifications – Optical

SFP-WDM51.36

Parameter	Symbol	Min.	Typical	Max.	Unit
9µm Core Diameter SMF	L	140			km
Data Rate		1.063		1.25	Gbps
Transmitter					
Center Wavelength	λ_c	1504	1510	1517	nm
Spectral Width (-20dB)	$\Delta\lambda$			1	nm
Side Mode Suppression Ratio	SMSR	30			dB
Average Output Power ^{*(note2)}	Pout	+2		+5	dBm
Extinction Ratio ^{*(note3)}	ER	8.2			dB
Rise/Fall Time(20%~80%)	tr/tf			0.26	ns
Total Jitter	TJ			56.5	ps
Output Optical Eye ^{*(note3)}	Compatible with IEEE 802.3ah-2004 ^{*(note5)}				
TX_Disable Assert Time	t_off			10	us
P _{out} @TX Disable Asserted	Pout			-45	dBm
Receiver					
Center Wavelength	λ_c	1564	1570	1577	nm
Receiver Sensitivity ^{*(note4)}	Pmin			-34	dBm

Receiver Overload	Pmax	-8			dBm
Return Loss		14			dB
Optical Path Penalty				1	dB
LOS De-Assert	LOSD			-35	dBm
LOS Assert	LOSA	-45			dBm
LOS Hysteresis ^{*(note6)}		0.5			dB

SFP-WDM57.36

Parameter	Symbol	Min.	Typical	Max.	Unit
9µm Core Diameter SMF	L	140			km
Data Rate		1.063		1.25	Gbps
Transmitter					
Center Wavelength	λ_c	1564	1570	1577	nm
Spectral Width (-20dB)	$\Delta\lambda$			1	nm
Side Mode Suppression Ratio	SMSR	30			dB
Average Output Power ^{*(note2)}	Pout	+2		+5	dBm
Extinction Ratio ^{*(note3)}	ER	8.2			dB
Rise/Fall Time(20%~80%)	tr/tf			0.26	ns
Total Jitter	TJ			56.5	ps
Output Optical Eye ^{*(note3)}	Compatible with IEEE 802.3ah-2004 ^{*(note5)}				
TX_Disable Assert Time	t_off			10	us
P _{out} @TX Disable Asserted	Pout			-45	dBm
Receiver					
Center Wavelength	λ_c	1504	1510	1517	nm
Receiver Sensitivity ^{*(note4)}	Pmin			-34	dBm
Receiver Overload	Pmax	-8			dBm
Return Loss		14			dB
Optical Path Penalty				1	dB
LOS De-Assert	LOSD			-35	dBm
LOS Assert	LOSA	-45			dBm
LOS Hysteresis ^{*(note6)}		0.5			dB

Note1: LVPECL logic, internally AC coupled.

Note2: Output is coupled into a 9/125µm single-mode fiber.

Note3: Filtered, measured with a PRBS 2⁷-1 test pattern@1250Mbps

Note4: Minimum average optical power measured at BER less than 1E-12, with a 2⁷-1 PRBS and ER=9 dB.

Note5: Eye pattern mask

Note6: LOS Hysteresis

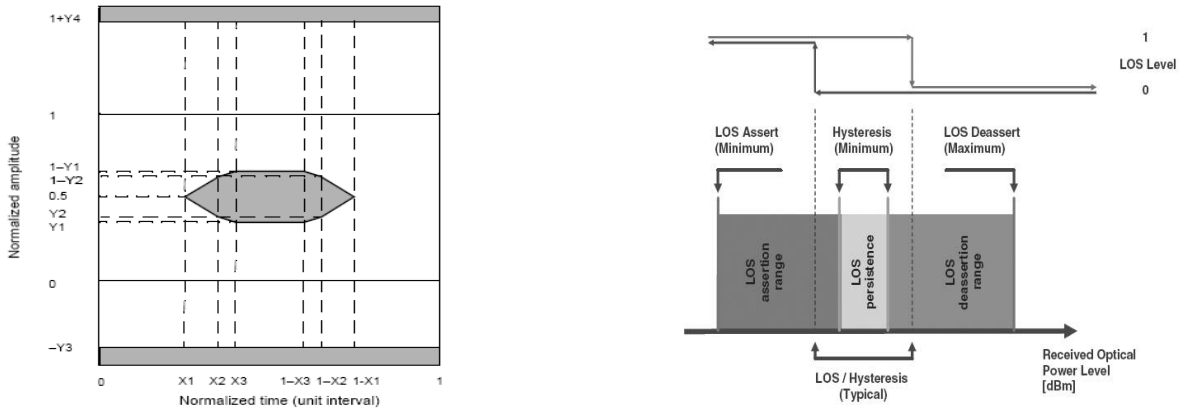

Functional Description of Transceiver

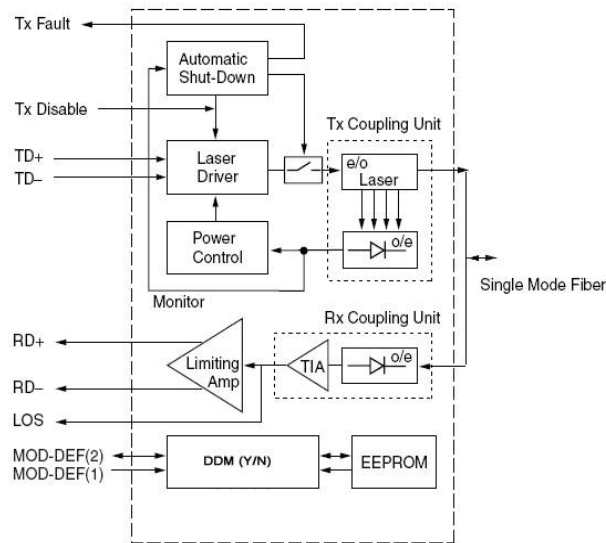

SFP Transceiver Electrical Pad Layout

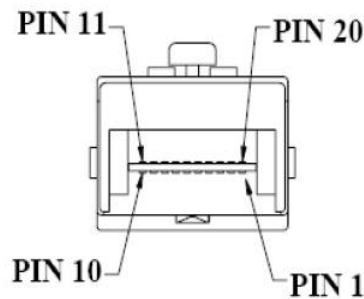
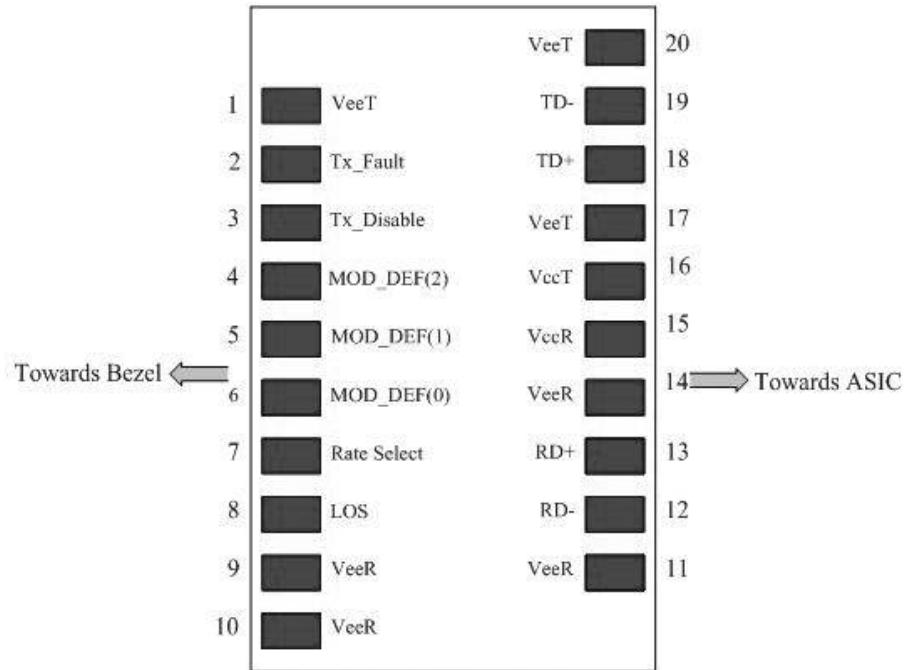

Pin Function Definitions

Pin Num.	Name	FUNCTION	Plug Seq.	Notes
1	VeeT	Transmitter Ground	1	5)
2	TX Fault	Transmitter Fault Indication	3	1)
3	TX Disable	Transmitter Disable	3	2) Module disables on high or open
4	MOD-DEF2	Module Definition 2	3	3) Data line for Serial ID.
5	MOD-DEF1	Module Definition 1	3	3) Clock line for Serial ID.
6	MOD-DEF0	Module Definition 0	3	3) Grounded within the module.
7	Rate Select	Not Connect	3	Function not available

8	LOS	Loss of Signal	3	4)
9	VeeR	Receiver Ground	1	5)
10	VeeR	Receiver Ground	1	5)
11	VeeR	Receiver Ground	1	5)
12	RD-	Inv. Received Data Out	3	6)
13	RD+	Received Data Out	3	7)
14	VeeR	Receiver Ground	1	5)
15	VccR	Receiver Power	2	3.3 ± 5%, 7)
16	VccT	Transmitter Power	2	3.3 ± 5%, 7)
17	VeeT	Transmitter Ground	1	5)
18	TD+	Transmit Data In	3	8)
19	TD-	Inv. Transmit Data In	3	8)
20	VeeT	Transmitter Ground	1	5)

Notes

1) TX Fault is an open collector/drain output, which should be pulled up with a 4.7K – 10KΩ resistor on the host board. Pull up voltage between 2.0V and VccT, R+0.3V. When high, output indicates a laser fault of some kind. Low indicates normal operation. In the low state, the output will be pulled to < 0.8V.

2) TX disable is an input that is used to shut down the transmitter optical output. It is pulled up within the module with a 4.7K – 10K Ω resistor. Its states are:

Low (0 – 0.8V): Transmitter on

(>0.8, < 2.0V): Undefined

High (2.0 – 3.465V): Transmitter Disabled

Open: Transmitter Disabled

3) Mod-Def 0,1,2. These are the module definition pins. They should be pulled up with a 4.7K – 10KΩ resistor on the host board. The pull-up voltage shall be VccT or VccR (see Section IV for further details). Mod-Def 0 is grounded by the module to indicate that the module is present Mod-Def 1 is the clock line of two wire serial interface for serial ID Mod-Def 2 is the data line of two wire serial interface for serial ID

4) LOS (Loss of Signal) is an open collector/drain output, which should be pulled up with a 4.7K – 10KΩ resistor. Pull up voltage between 2.0V and VccT, R+0.3V. When high, this output indicates the received optical power is below the worst-case receiver sensitivity (as defined by the standard in use). Low indicates normal operation. In the low state, the output will be pulled to < 0.8V.

5) VeeR and VeeT may be internally connected within the SFP module.

6) RD-/+ : These are the differential receiver outputs. They are AC coupled 100Ω differential lines which should be terminated with 100Ω (differential) at the user SERDES. The AC coupling is done inside the module and is thus not required on the host board. The voltage swing on these lines will be between 370 and 2000 mV differential (185 – 1000 mV single ended) when properly terminated.

7) VccR and VccT are the receiver and transmitter power supplies. They are defined as 3.3V ±5% at the SFP connector pin. Maximum supply current is 300mA. Recommended host board power supply filtering is shown below. Inductors with DC resistance of less than 1 ohm should be used in order to maintain the required voltage at the SFP input pin with 3.3V supply voltage. When the recommended supply-filtering network is used, hot plugging of the SFP transceiver module will result in an inrush current of no more than 30mA greater than the steady state value. VccR and VccT may be internally connected within the SFP transceiver module.

8) TD-/+ : These are the differential transmitter inputs. They are AC-coupled, differential lines with 100Ω differential termination inside the module. The AC coupling is done inside the module and is thus not required on the host board. The inputs will accept differential swings of 500 – 2400 mV (250 – 1200mV single-ended),

though it is recommended that values between 500 and 1200 mV differential (250 – 600mV single-ended) be used for best EMI performance.

EEPROM

The serial interface uses the 2-wire serial CMOS EEPROM protocol defined for the ATMEL AT24C02/04 family of components. When the serial protocol is activated, the host generates the serial clock signal (SCL). The positive edge clocks data into those segments of the EEPROM that are not writing protected within the SFP transceiver. The negative edge clocks data from the SFP transceiver. The serial data signal (SDA) is bi-directional for serial data transfer. The host uses SDA in conjunction with SCL to mark the start and end of serial protocol activation. The memories are organized as a series of 8-bit data words that can be addressed individually or sequentially.

The Module provides diagnostic information about the present operating conditions. The transceiver generates this diagnostic data by digitization of internal analog signals. Calibration and alarm/warning threshold data is written during device manufacture. Received power monitoring, transmitted power monitoring, bias current monitoring, supply voltage monitoring and temperature monitoring all are implemented. The diagnostic data are raw A/D values and must be converted to real world units using calibration constants stored in EEPROM locations 56 – 95 at wire serial bus address A2H. The digital diagnostic memory map specific data field define as following .For detail EEPROM information, please refer to the related document of SFF 8472 Rev 9.3.

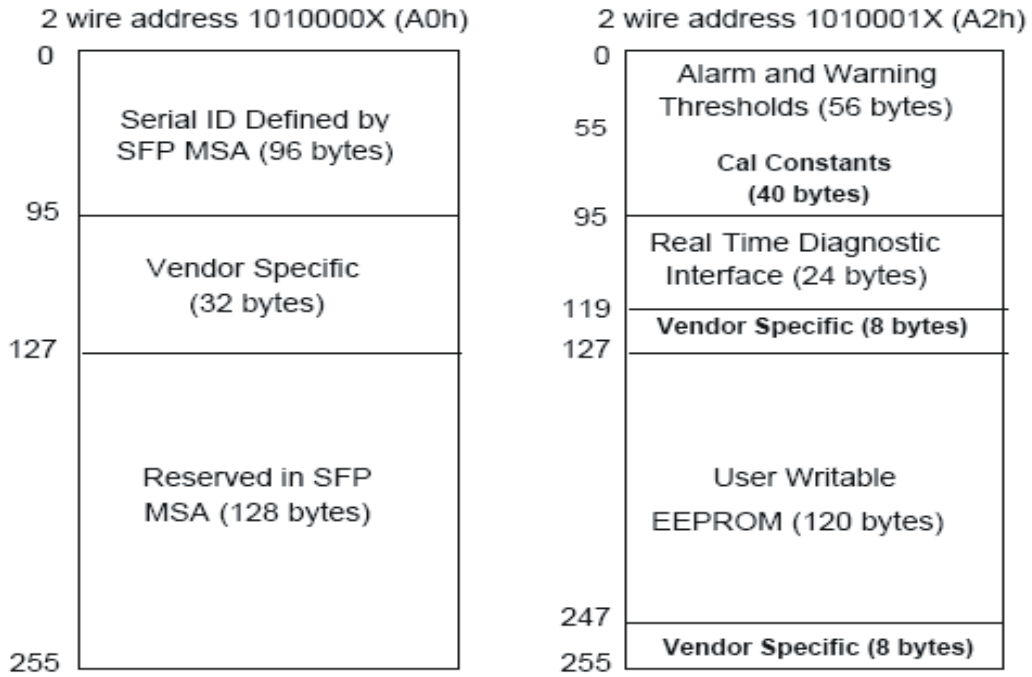

EEPROM Serial ID Memory Contents

Accessing Serial ID Memory uses the 2 wire address 1010000X (A0H). Memory Contents of Serial ID are shown in Table 1.

Table 1 Serial ID Memory Contents

Addr.	Size (Bytes)	Name of Field	Hex	Description
BASE ID FIELDS				
0	1	Identifier	03	SFP
1	1	Ext. Identifier	04	SFP function is defined by serial ID only
2	1	Connector	XX	SC Connector
3-10	8	Transceiver	00 00 00 22 00 00 00 00	Transmitter Code
11	1	Encoding	01	8B10B
12	1	BR, Nominal	0D	1.25Gbps
13	1	Reserved	00	
14	1	Length (9µm)km	78	Transceiver transmit distance
15	1	Length(9µm)100m	00	
16	1	Length (50µm) 10m	00	
17	1	Length(62.5µm)10m	00	
18	1	Length (Copper)	00	Not compliant
19	1	Reserved	00	
20-35	16	Vendor name	XX XX XX XX XX XX XX XX ^(note9) 20 20 20 20 20 20	Vendor name (ASCII)

			20	
36	1	Reserved	00	
37-39	3	Vendor OUI	XX XX XX ^(note9)	
40-55	16	Vendor PN		Transceiver part number
56-59	4	Vendor rev	XX XX XX XX ^(note9)	
60-61	2	Wavelength	XX XX	1550nm/1490nm 1510nm/1570nm
62	1	Reserved	00	
63	1	CC_BASE	Check Sum (Variable)	Check code for Base ID Fields
EXTENDED ID FIELDS				
64-65	2	Options	00 1A	TX_DISABLE, TX_FAULT and Loss of Signal implemented.
66	1	BR,max	00	
67	1	BR,min	00	
68-83	16	Vendor SN	XX XX XX XX XX XX XX XX 20 20 20 20 20 20 20 20 ^(note9)	Serial Number of transceiver (ASCII). For example "B000822".
84-91	8	Date code	XX XX XX XX XX XX XX XX ^(note9)	Manufactory date code. For example "080405".
92	1	Diagnostic Monitoring Type	XX ^(note9)	Digital diagnostic monitoring implemented
93	1	Enhanced Options	XX ^(note9)	Optional flags
94	1	SFF_8472 Compliance	XX ^(note9)	01 for diagnostics (Rev9.3 SFF-8472).
95	1	CC_EXT	Check Sum (Variable)	Check sum for Extended ID Field.
VENDOR SPECIFIC ID FIELDS				
96-127	32	Vendor Specific	Read only	Depends on customer information
128-255	128	Reserved	Read only	

Note9: The "xx" byte should be filled in according to practical case. For more information, please refer to the related document of SFP Multi-Source Agreement (MSA).

Recommended Circuit Schematic

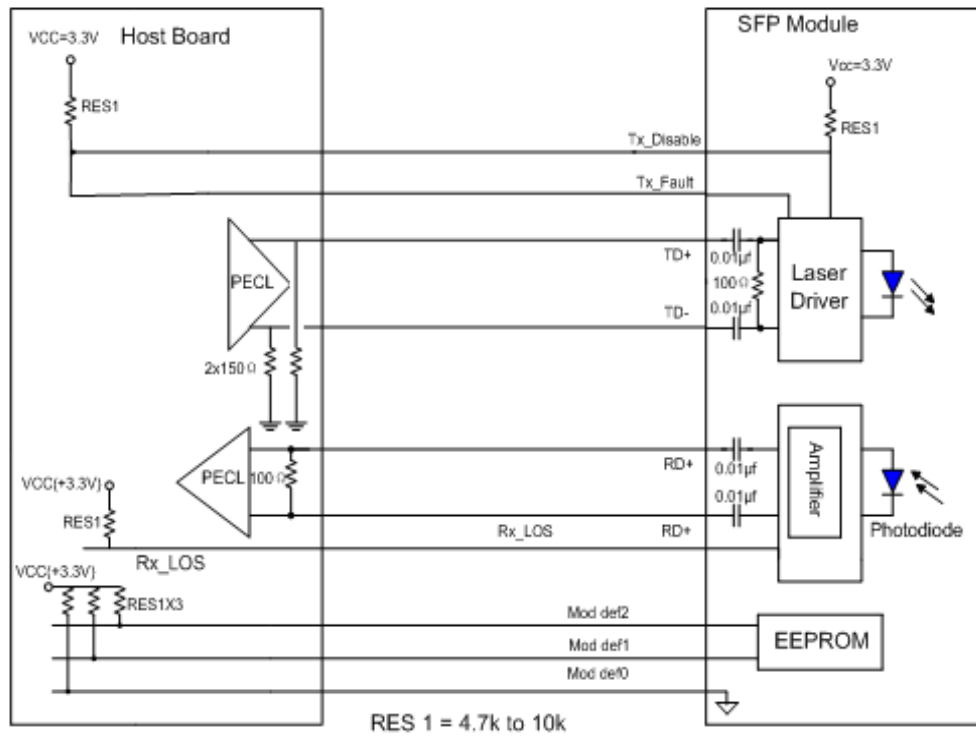

Mechanical Specifications

