

Особенности:

- 1310нм DFB лазер для SFP-MR.WDM3.40
- 1550нм DFB лазер для SFP-MR.WDM5.40
- 40км бюджет на SMF
- возможность горячей замены
- SC разъем
- встроенная функция диагностики (DDMI) в соответствии с SFF-8472
- 2.67Gbps Data rate

Области применения:

- 1Fiber Channel, Gigabit Ethernet
- OC-48 / STM-16

Absolute Maximum Ratings

Parameter	Symbol	Min.	Typical	Max.	Unit
Operating Case Temperature	T_A	0		+70	°C
Power Supply Voltage	V_{CC}	3.15	3.3	3.45	V
Power Supply Current	I_{CC}			300	mA
Date Rate	FC		1.063		Gbps
	2xFC		2.125		Gbps
	OC-48/STM-16		2.5		Gbps

Performance Specifications - Electrical

Parameter	Symbol	Min.	Typ.	Max	Unit	Notes
Transmitter						
LVPECL Compatible Inputs(Differential)	V_{in}	400		2000	mVpp	AC coupled inputs*(note5)
Input Impedance (Differential)	Z_{in}	85	100	115	ohms	$R_{in} > 100 \text{ kohms @ DC}$
Tx_Dis	Disable	2		V_{CC}	V	
	Enable	0		0.8		
Tx_FAULT	Fault	2		$V_{CC}+0.3$	V	
	Normal	0		0.5		
Receiver						
CML Outputs (Differential)	V_{out}	370		1200	mVpp	AC coupled outputs*(note5)
Output Impedance (Differential)	Z_{out}	85	100	115	ohms	
Rx_LOS	LOS	2		$V_{CC}+0.3$	V	

	Normal		0		0.8	V	
MOD_DEF (0:2)	VoH		2.5			V	With Serial ID
	VoL		0		0.5	V	

Optical and Electrical Characteristics

(SFP-MR.WDM3.40, 1310nm DFB and PIN, 40km)

Parameter	Symbol	Min.	Typical	Max.	Unit
9µm Core Diameter SMF	L		40		km
Data Rate		1.063		2.67	Gbps
Transmitter					
Centre Wavelength	λ_c	1260	1310	1360	nm
Spectral Width (-20dB)	$\Delta\lambda$			1	nm
Side Mode Suppression Ratio	SMSR	30			dB
Average Output Power ^{*(note3)}	P _{out}	0		5	dBm
Extinction Ratio ^{*(note4)}	ER	8.2			dB
Rise/Fall Time(20%~80%)	tr/tf			150	ps
Output Optical Eye ^{*(note4)}	Compatible with ITU-T G.957 ^{*(note7)}				
TX_Disable Assert Time	t _{off}			10	µs
P _{out@TX Disable Asserted}	P _{out}			-45	dBm
Receiver					
Centre Wavelength	λ_c	1500	1550	1580	nm
Receiver Sensitivity ^{*(note6)}	P _{min}			-20	dBm
Receiver Overload	P _{max}	0			dBm
Reflection				-27	dB
LOS De-Assert	LOSD			-19	dBm
LOS Assert	LOSA	-45			dBm
LOS Hysteresis ^{*(note8)}		0.5			dB

(SFP-MR.WDM5.40, 1550nm DFB and PIN, 40km)

Parameter	Symbol	Min.	Typical	Max.	Unit
9µm Core Diameter SMF	L		20		km
Data Rate		1.063		2.67	Gbps
Transmitter					
Centre Wavelength	λ_c	1530	1550	1570	nm
Spectral Width (-20dB)	$\Delta\lambda$			1	nm
Average Output Power ^{*(note3)}	P _{out}	0		5	dBm
Extinction Ratio ^{*(note4)}	ER	8.2			dB
Side Mode Suppression Ratio	SMSR	30			dB
Rise/Fall Time(20%~80%)	tr/tf			150	ps
Output Optical Eye ^{*(note4)}	Compatible with ITU-T G.957 ^{*(note7)}				
TX_Disable Assert Time	t _{off}			10	µs
Receiver					
Centre Wavelength	λ_c	1260		1360	nm
Receiver Sensitivity ^{*(note6)}	P _{min}			-20	dBm
Receiver Overload	P _{max}	0			dBm

Reflection				-27	dB
Optical Path Penalty				1	dB
LOS De-Assert	LOSD			-19	dBm
LOS Assert	LOSA	-45			dBm
LOS Hysteresis*(note8)		0.5			dB

Note3: Output is coupled into a 9/125µm single-mode fiber.

Note4: Filtered, measured with a PRBS 2²³-1 test pattern @2500Mbps

Note5: LVPECL/CML logic, internally AC coupled.

Note6: Measured at all data rates specified in Data Rate table with ER=9 dB, 2²³-1 PRBS data pattern, BER <1E-10.

Note7: Eye pattern mask

Note8: LOS Hysteresis

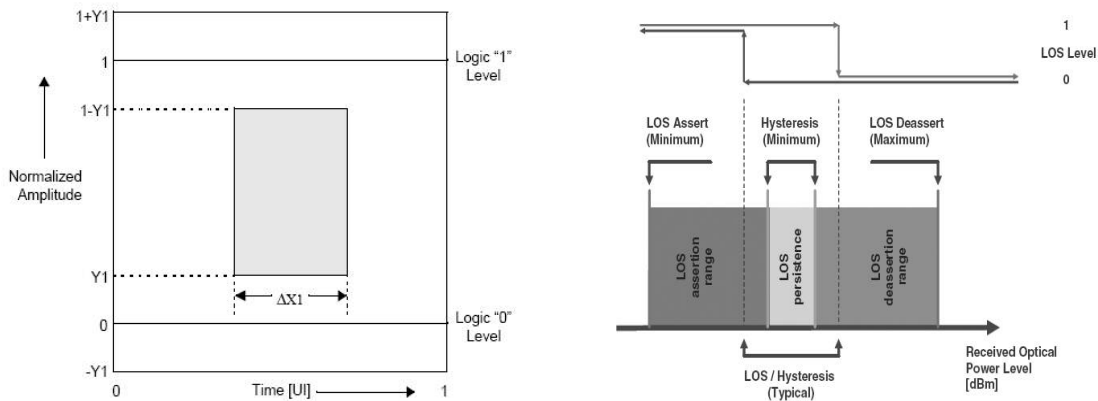

Functional Description of Transceiver

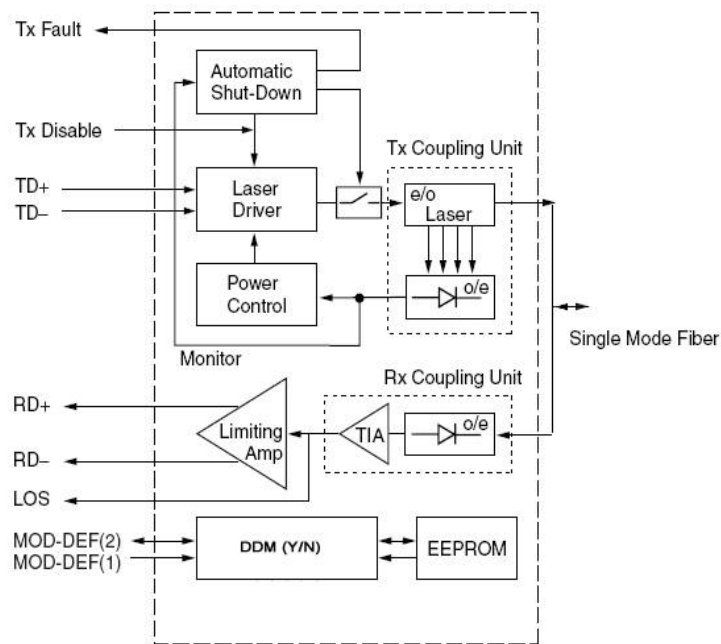

SFP Transceiver Electrical Pad Layout

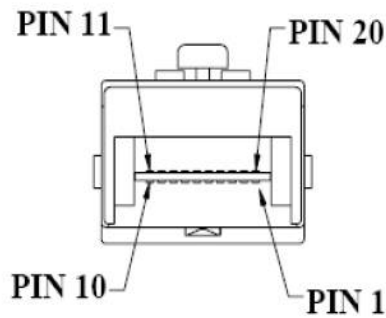
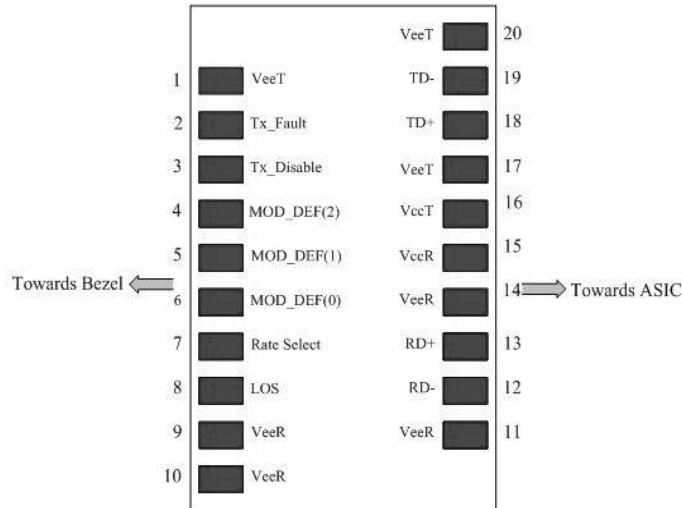

Pin Function Definitions

Pin Num.	Name	FUNCTION	Plug	Notes
1	VeeT	Transmitter Ground	1	5)
2	TX Fault	Transmitter Fault Indication	3	1)
3	TX Disable	Transmitter Disable	3	2), Module disables on high or open
4	MOD-DEF2	Module Definition 2	3	3), Data line for Serial ID.
5	MOD-DEF1	Module Definition 1	3	3), Clock line for Serial ID.
6	MOD-DEF0	Module Definition 0	3	3), Grounded within the module.
7	Rate Select	Not Connect	3	Function not available
8	LOS	Loss of Signal	3	4)
9	VeeR	Receiver Ground	1	5)

10	VeeR	Receiver Ground	1	5)
11	VeeR	Receiver Ground	1	5)
12	RD-	Inv. Received Data Out	3	6)
13	RD+	Received Data Out	3	7)
14	VeeR	Receiver Ground	1	5)
15	VccR	Receiver Power	2	3.3 ± 5%, 7)
16	VccT	Transmitter Power	2	3.3 ± 5%, 7)
17	VeeT	Transmitter Ground	1	5)
18	TD+	Transmit Data In	3	8)
19	TD-	Inv. Transmit Data In	3	8)
20	VeeT	Transmitter Ground	1	5)

Notes:

- 1) TX Fault is an open collector/drain output, which should be pulled up with a 4.7K – 10KΩ resistor on the host board. Pull up voltage between 2.0V and VccT, R+0.3V. When high, output indicates a laser fault of some kind. Low indicates normal operation. In the low state, the output will be pulled to < 0.8V.
- 2) TX disable is an input that is used to shut down the transmitter optical output. It is pulled up within the module with a 4.7 – 10 K Ω resistor. Its states are:
 Low (0 – 0.8V): Transmitter on
 (>0.8, < 2.0V): Undefined
 High (2.0 – 3.465V): Transmitter Disabled
 Open: Transmitter Disabled
- 3) Mod-Def 0,1,2. These are the module definition pins. They should be pulled up with a 4.7K – 10KΩ resistor on the host board. The pull-up voltage shall be VccT or VccR (see Section IV for further details). Mod-Def 0 is grounded by the module to indicate that the module is present Mod-Def 1 is the clock line of two wire serial interface for serial ID Mod-Def 2 is the data line of two wire serial interface for serial ID
- 4) LOS (Loss of Signal) is an open collector/drain output, which should be pulled up with a 4.7K – 10KΩ resistor. Pull up voltage between 2.0V and VccT, R+0.3V. When high, this output indicates the received optical power is below the worst-case receiver sensitivity (as defined by the standard in use). Low indicates normal operation. In the low state, the output will be pulled to < 0.8V.
- 5) VeeR and VeeT may be internally connected within the SFP module.
- 6) RD-/+ : These are the differential receiver outputs. They are AC coupled 100Ω differential lines which should be terminated with 100Ω (differential) at the user SERDES. The AC coupling is done inside the module and is thus not required on the host board. The voltage swing on these lines will be between 370 and 2000 mV differential (185 –1000 mV single ended) when properly terminated.
- 7) VccR and VccT are the receiver and transmitter power supplies. They are defined as 3.3V ±5% at the SFP connector pin. Maximum supply current is 300mA. Recommended host board power supply filtering is shown below. Inductors with DC resistance of less than 1 ohm should be used in order to

maintain the required voltage at the SFP input pin with 3.3V supply voltage. When the recommended supply-filtering network is used, hot plugging of the SFP transceiver module will result in an inrush current of no more than 30mA greater than the steady state value. VccR and VccT may be internally connected within the SFP transceiver module.

8) TD-/+: These are the differential transmitter inputs. They are AC-coupled, differential lines with 100Ω differential termination inside the module. The AC coupling is done inside the module and is thus not required on the host board. The inputs will accept differential swings of 500 – 2400 mV (250 – 1200mV single-ended), though it is recommended that values between 500 and 1200 mV differential (250 – 600mV single-ended) be used for best EMI performance.

EEPROM

The serial interface uses the 2-wire serial CMOS EEPROM protocol defined for the ATMEL AT24C02/04 family of components. When the serial protocol is activated, the host generates the serial clock signal (SCL). The positive edge clocks data into those segments of the EEPROM that are not writing protected within the SFP transceiver. The negative edge clocks data from the SFP transceiver. The serial data signal (SDA) is bi-directional for serial data transfer. The host uses SDA in conjunction with SCL to mark the start and end of serial protocol activation. The memories are organized as a series of 8-bit data words that can be addressed individually or sequentially.

The Module provides diagnostic information about the present operating conditions. The transceiver generates this diagnostic data by digitization of internal analog signals. Calibration and alarm/warning threshold data is written during device manufacture. Received power monitoring, transmitted power monitoring, bias current monitoring, supply voltage monitoring and temperature monitoring all are implemented. The diagnostic data are raw A/D values and must be converted to real world units using calibration constants stored in EEPROM locations 56 – 95 at wire serial bus address A2h. The digital diagnostic memory map specific data field define as following .For detail EEPROM information, please refer to the related document of SFF 8472 Rev 9.3.

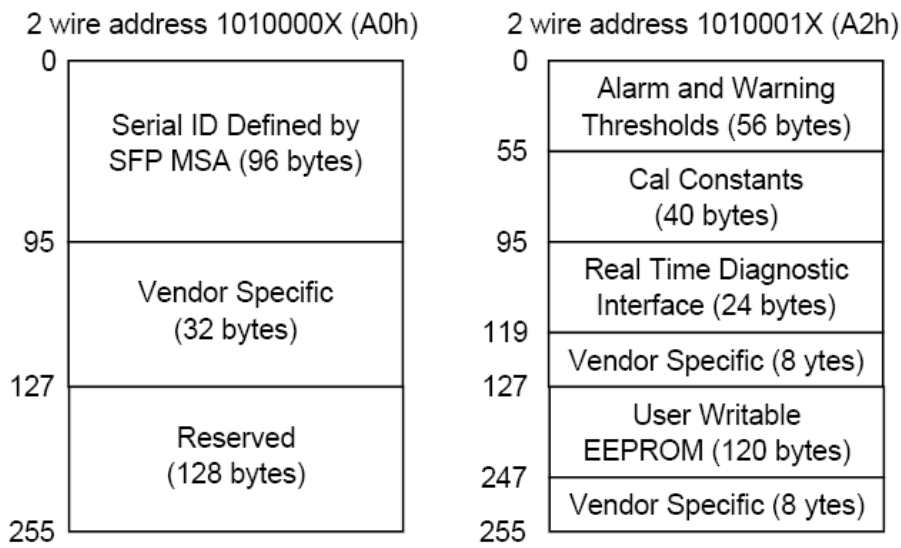

Recommend Circuit Schematic

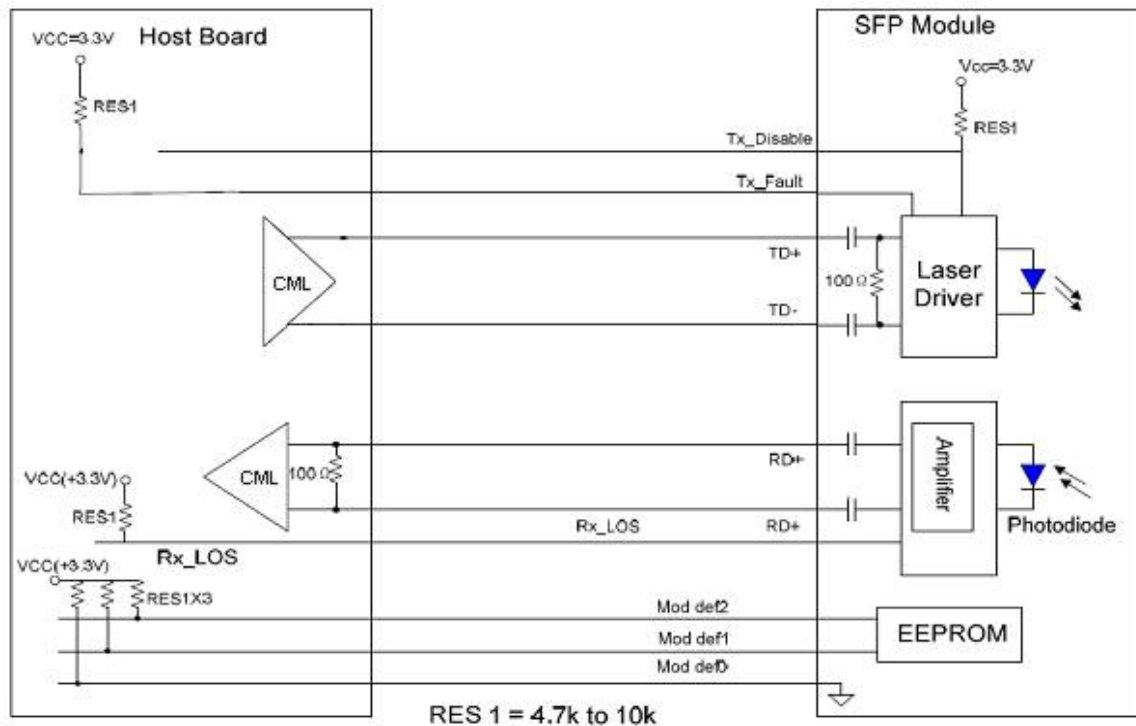

Mechanical Specifications

