

SFP модуль предназначен для создания линии связи до 20км по одномодовому кабелю.

**Особенности:**

- 155Mbps SM
- возможность горячей замены
- двойной LC разъем
- детальная информация о модули в EEPROM
- соответствие спецификации SFF-8472 SFP MSA

**Области применения:**

- Fast Ethernet 100Base-FX
- STM-1

**Функциональная схема:**

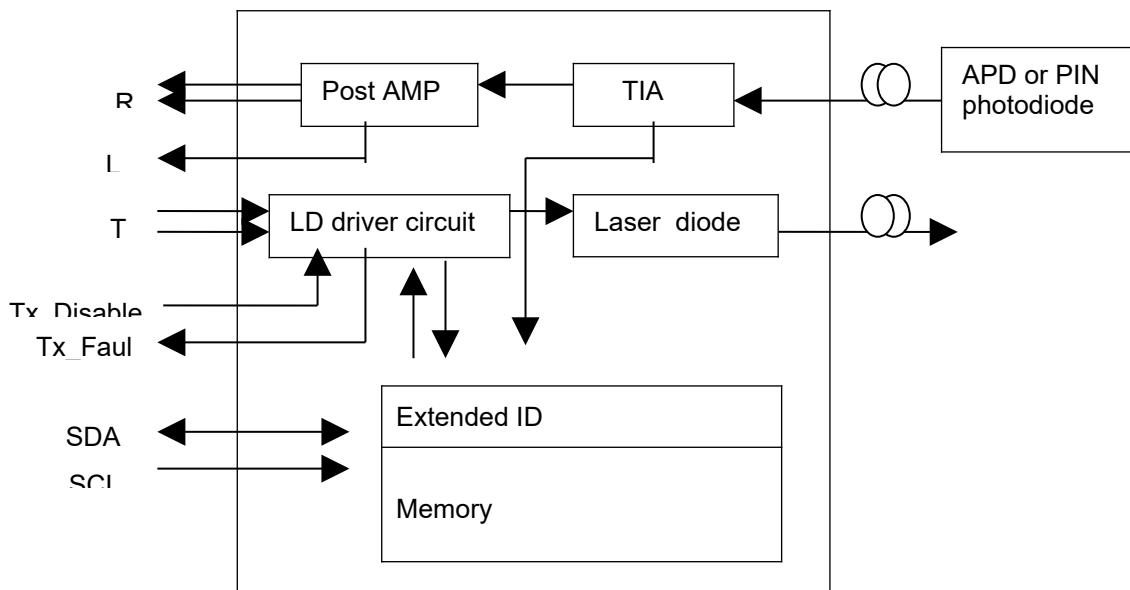

**Спецификация:**

Максимальный режим эксплуатации				
параметр	обозначение	минимум	максимум	единица измерения
Напряжение питания	VCC	0	+3,6	V
Рабочая температура	Top	0	+75	°C
Рекомендованный режим эксплуатации				
параметр	обозначение	минимум	максимум	единица измерения
Напряжение	VCC	+3,1	+3,6	V

Максимальный режим эксплуатации					
питания					
Рабочая температура	Top	-5	+70		°C
Оптические характеристики					
параметр	обозначение	минимум	типовое	максимум	единица измерения
Передатчик					
Выходная мощность	$P_0$	<b>-15</b>		-8	dBm
Отношение Исчезновения	ER	8,2	-	-	dB
Длина волны	$\lambda$	1260	1310	1360	nm
Ширина спектра	$\Delta\lambda$	-	-	4	nm
Выход передатчика	IUT-T G.957 Compliant				
Приемник					
Чувствительность	Sen	-	-	<b>-28</b>	dBm
Длина волны	$\lambda$	1260	-	1600	nm
Детектирование сигнала	$P_A$	-	-	-29	dBm
Максимальная мощность на фотоприемнике	$P_{max}$	-8	-	-	dBm
Электрические характеристики					
параметр	обозначение	минимум	типовое	максимум	единица измерения
Передатчик					
Напряжение питания	$V_{CCT}$	+3,1	+3,3	+3,6	V
Ток потребления	$I_{CCT}$	-	80	150	mA
High уровень	$V_{IH}$	$V_{CCT} - 1,165$	-	$V_{CCT} - 0,700$	V
Low уровень	$V_{IL}$	$V_{CCT} - 1,890$	-	$V_{CCT} - 1,475$	V
Напряжение разрешающее передачу	$V_{EN}$	-	-	0,8	V
Напряжение запрещающее передачу	$V_D$	2	-	-	V
Приемник					
Напряжение питания	$V_{CCR}$	+3,1	+3,3	+3,6	V

параметр	обозначение	минимум	типовое	максимум	единица измерения
Ток потребления	$I_{CCR}$	-	80	150	mA
High уровень	$V_{OH}$	$V_{CCR} - 1,025$	-	$V_{CCR} - 0,880$	V
Low уровень	$V_{OL}$	$V_{CCR} - 1,810$	-	$V_{CCR} - 1,620$	V
LOS High уровень	$V_{LOUT}$	-	-	0,8	V
LOS Low уровень	$V_{HOUT}$	2	-	-	V

Рекомендованная схема включения:

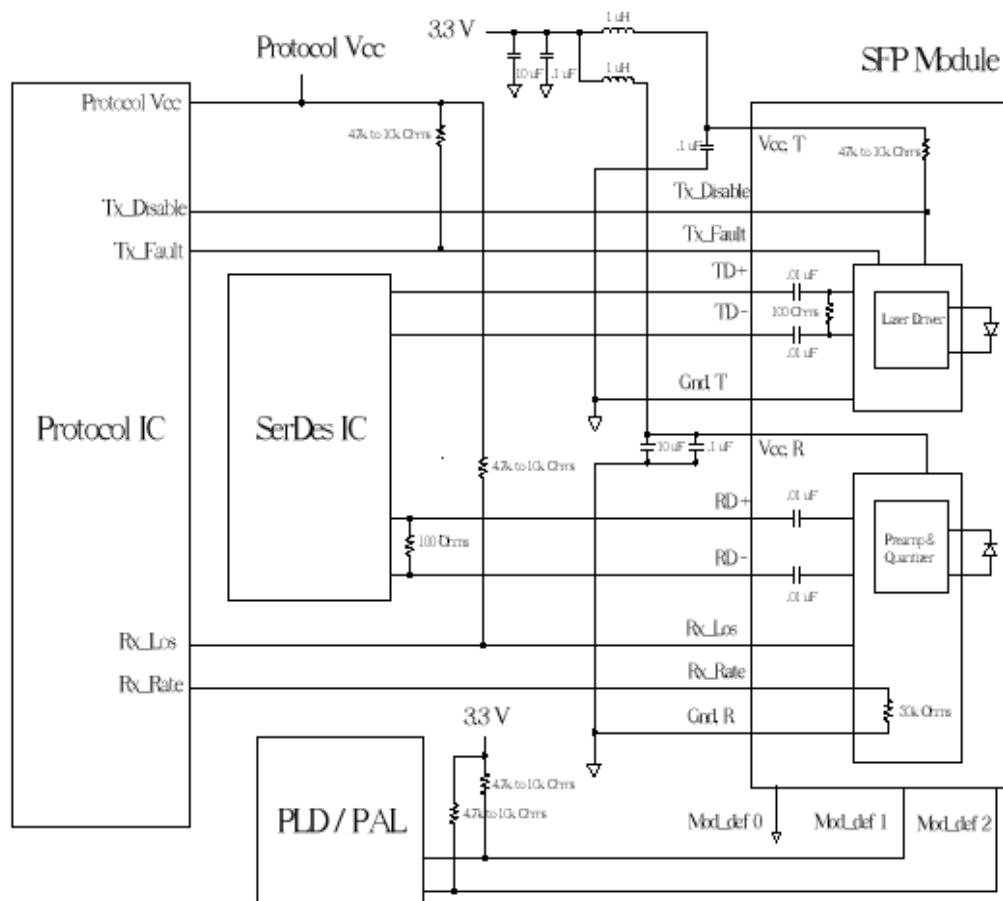

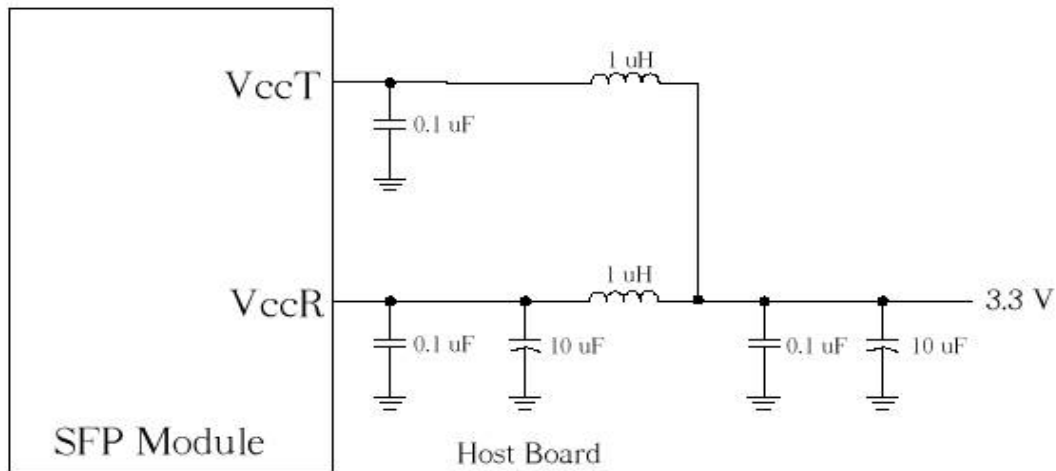
**Описание контактов (PIN):**

Pin Name	PIN	Name/Function
GNDR	9, 10, 11, 14	Receiver Ground
VCCR	15	Receiver Supply Voltage. They are defined as $+3.3V \pm 5\%$ at the SFP connector pin. Recommended host board power supply filtering is shown below. The DC resistance of inductor is less than $1 \Omega$ , which result in maintaining the required voltage at the SFP input pin with $+3.3V$ supply voltage.
RD-	12	Receiver Data, Differential Output. They are AC coupled $100 \Omega$ differential lines which should be terminated with $100 \Omega$ at the user SERDES. The AC coupling is done inside the module and is thus not required on the host board. The voltage swing on these lines will be between 370mV and 2000mV differential when properly terminated.
RD+	13	Receiver Data, Differential Output. They are AC coupled $100 \Omega$ differential lines which should be terminated with $100 \Omega$ at the user SERDES. The AC coupling is done inside the module and is thus not required on the host board. The voltage swing on these lines will be between 370mV and 2000mV differential when properly terminated.
LOS	8	Receiver Loss of Signal, logic high, open collector compatible, 4.7K to 10K Ohm pull up to VCCR on host
Rate Select	7	NC.
GNDT	1, 17, 20	Transmitter Ground
VCCT	16	Transmitter Supply Voltage. They are defined as $+3.3V \pm 5\%$ at the SFP connector pin. Recommended host board power supply filtering is shown below. The DC resistance of inductor is less than $1 \Omega$ , which result in maintaining the required voltage at the SFP input pin with $+3.3V$ supply voltage.
TD+	18	Transmit Data, Differential Input. They are AC coupled $100 \Omega$ differential lines which should be terminated with $100 \Omega$ inside the module. The AC coupling is done inside the module and is thus not required on the host board.
TD-	19	Transmit Data, Differential Input. They are AC coupled $100 \Omega$ differential lines which should be terminated with $100 \Omega$ inside the module. The AC coupling is done inside the module and is thus not required on the host board.



The serial interface uses the 2-wire serial CMOS EEPROM protocol defined for the ATMEL AT24C02/04 family of components. When the serial protocol is activated, the host generates the serial clock signal (SCL). The positive edge clocks data into those segments of the EEPROM that are not write protected within the SFP+ transceiver. The negative edge clocks data from the SFP+ transceiver. The serial data signal (SDA) is bi-directional for serial data transfer. The host uses SDA in conjunction with SCL to mark the start and end of serial protocol activation. The memories are organized as a series of 8-bit data words that can be addressed individually or sequentially.

The Module provides diagnostic information about the present operating conditions. The transceiver generates this diagnostic data by digitization of internal analog signals. Calibration and alarm/warning threshold data is written during device manufacture. Received power monitoring, transmitted power monitoring, bias current monitoring, supply voltage monitoring and temperature monitoring all are implemented. The diagnostic data are raw A/D values and must be converted to real world units using calibration constants stored in EEPROM locations 56 – 95 at wire serial bus address A2h. The digital diagnostic memory map specific data field define as following.

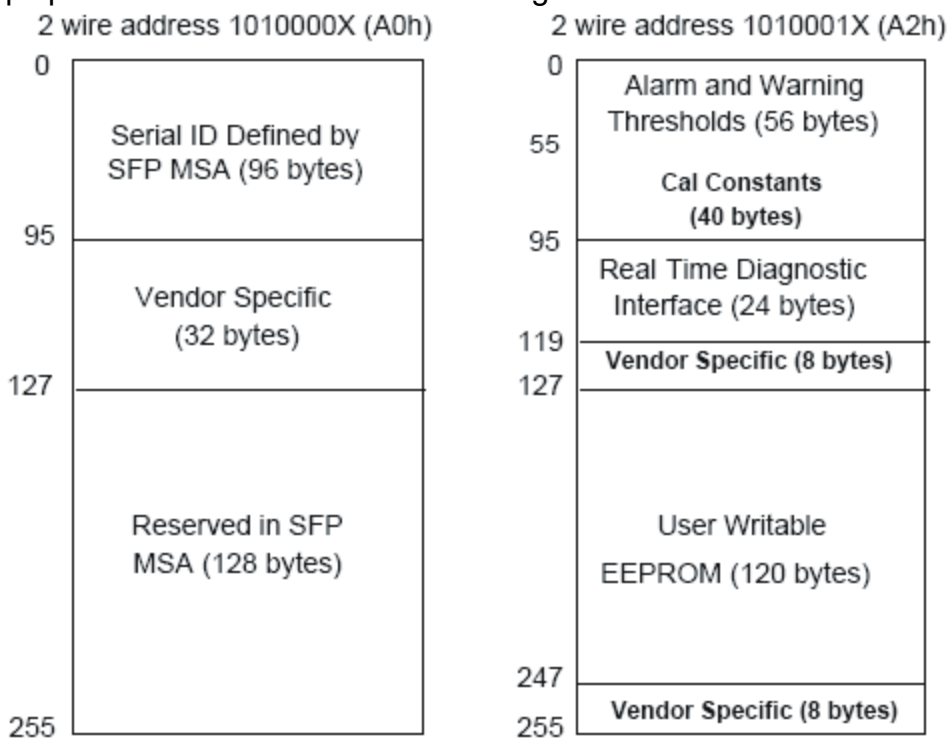

**Mechanical Specifications**

