

Multi-Mode 40GBASE-SR4 QSFP+ Transceiver**Особенности:**

- соответствие стандарту IEEE 802.3ba (40GBASE-SR4)
- соответствие QSFP+ MSA SFF-8436 спецификации
- до 100м на OM3 кабеле и до 150м на OM4 многомодовом оптическом кабеле
- VCSEL array лазерный передатчик и PIN array фотоприемник
- одно напряжение питания 3,3В
- мощность рассеивания менее 1,5Вт
- частота до 10.3125Gbps на канал
- рабочая температура 0°C~+70°C
- Digital Diagnostic Monitoring
- использование стандартного 12/8 жильного оптического кабеля с MPO коннектором

Области применения:

- 40GBE and 10GBE interconnects
- Datacom/Telecom switch & router connections
- Data aggregation and backplane applications
- Proprietary protocol and density application

Part No.	Data Rate	Fiber	Distance ^{*(note1)}	Interface	Temp.	DD MI
QSFP-Plus-SR	40Gbps	MMF	100m/150m	MPO	0°C~+70°C	Yes

Note1: 100m with OM3 MMF and 150m with OM4 MMF

Absolute Maximum Ratings

Parameter	Symbol	Min.	Max.	Unit
Storage Temperature	Ts	-40	+85	°C
Supply Voltage	Vcc	-0.5	3.6	V
Operating Relative Humidity	RH	5	85	%

*Exceeding any one of these values may destroy the device immediately.

Recommended Operating Conditions

Parameter	Symbol		Min.	Typical	Max.	Unit
Operating Case Temperature	T _A	QSFP-Plus-SR	0		+70	°C
Power Supply Voltage	V _{CC}		3.15	3.3	3.45	V
Power Supply Current	I _{CC}				475	mA
Aggregate Bit Rate	BR _{AVE}			41.25		Gbps
Lane Bit Rate	BR _{LANE}			10.3125		Gbps

Performance Specifications - Electrical

Parameter	Symbol	Min.	Typ.	Max	Unit	Notes
Transmitter						
Single ended input voltage tolerance		-0.3		4	V	Referred to TP1 signal common
AC common mode input voltage tolerance		15			mV	RMS
Input Impedance (Differential)	Z _{in}	85	100	115	ohms	R _{in} > 100 kohms @ DC
TX Disable	Disable	V _{IH}	2	V _{CC} +0.3	V	
	Enable	V _{IL}	0	0.8		
TX FAULT	Fault	V _{OH}	2.4	V _{CC} +0.3	V	
	Normal	V _{OL}	0	0.5		
Receiver						
Single ended output voltage		-0.3		4	V	Referred to signal common
AC common mode voltage				7.5	mV	RMS
Termination mismatch at 1MHz				5	%	
Output Impedance (Differential)	Z _{out}	85	100	115	ohms	
Output Rise/Fall Time	t _r /t _f	30			ps	10%~90%
RX_LOS	LOS	V _{OH}	2.4	V _{CC} +0.3	V	
	Normal	V _{OL}	0	0.8	V	

Optical and Electrical Characteristics

Parameter	Symbol	Min	Typical	Max	Unit
OM3 MMF	L	0.5	-	100	m
Aggregate Bit Rate	BR _{AVE}	-	40	-	Gbps
Per Lane Bit Rate	BR _{LANE}	-	10.3125	-	Gbps
Transmitter					
Center Wavelength	λ _c	840	850	860	nm
RMS spectral width	RMS	-	-	0.65	nm
Average Launch Power, Each Lane ^{*(note2)}	P _{out} /lane	-7.6	-	2.4	dBm
Transmit OMA, per Lane	TX_OMA/lane	-5.6	-	3	dBm

Difference in launch power between any two lanes(OMA)		-	-	4	dB
Peak power, each lane		-	-	4	dBm
Transmitter and dispersion penalty, each lane	TDP/lane	-	-	3.5	dB
Extinction Ratio*(note3)	ER	3	-	-	dB
Optical Return Loss Tolerance		-	-	12	dB
Average launch power of OFF, each lane		-	-	-30	dBm
Output Optical Eye*(note3)	IEEE 802.3ba-2010 Compliant				
TX Disable Assert Time	t_off	-	-	100	us
Receiver					
Center Wavelength	λ_c	840	850	860	nm
Damage Threshold		3.4	-	-	dB
Sensitivity	Ps	-9.5			dBm
Stressed receiver sensitivity in OMA, each lane	Pmins	-	-	-5.4	dBm
Maximum Receive Power, each lane	Pmax	-	-	2.4	dBm
Average power, each lane	RX/lane	-7.9	-	+1.0	dBm
LOS De-Assert, OMA	LOSD	-	-	-7.5	dBm
Receiver reflectance	Rr	-	-	-12	dB
LOS Assert	LOSA	-30	-	-	dBm
LOS Hysteresis*(note6)		0.5	-	-	dB

Note2: Output is coupled into a 50/125µm multi-mode fiber.

Note3: Filtered, measured with a PRBS 2³¹-1 test pattern @10.3125Gbps

Note4: High speed I/O, internally AC coupled.

Note5: Minimum average optical power measured at BER less than 1E-12, with a 2³¹-1 PRBS.

Note6: LOS Hysteresis

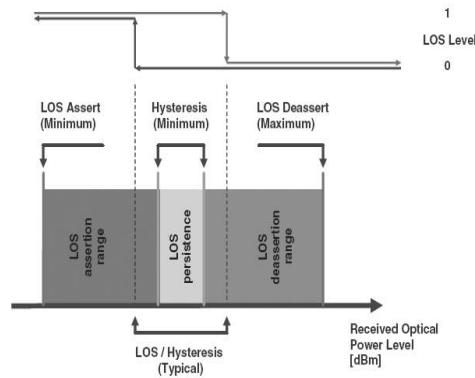

Functional Description of Transceiver

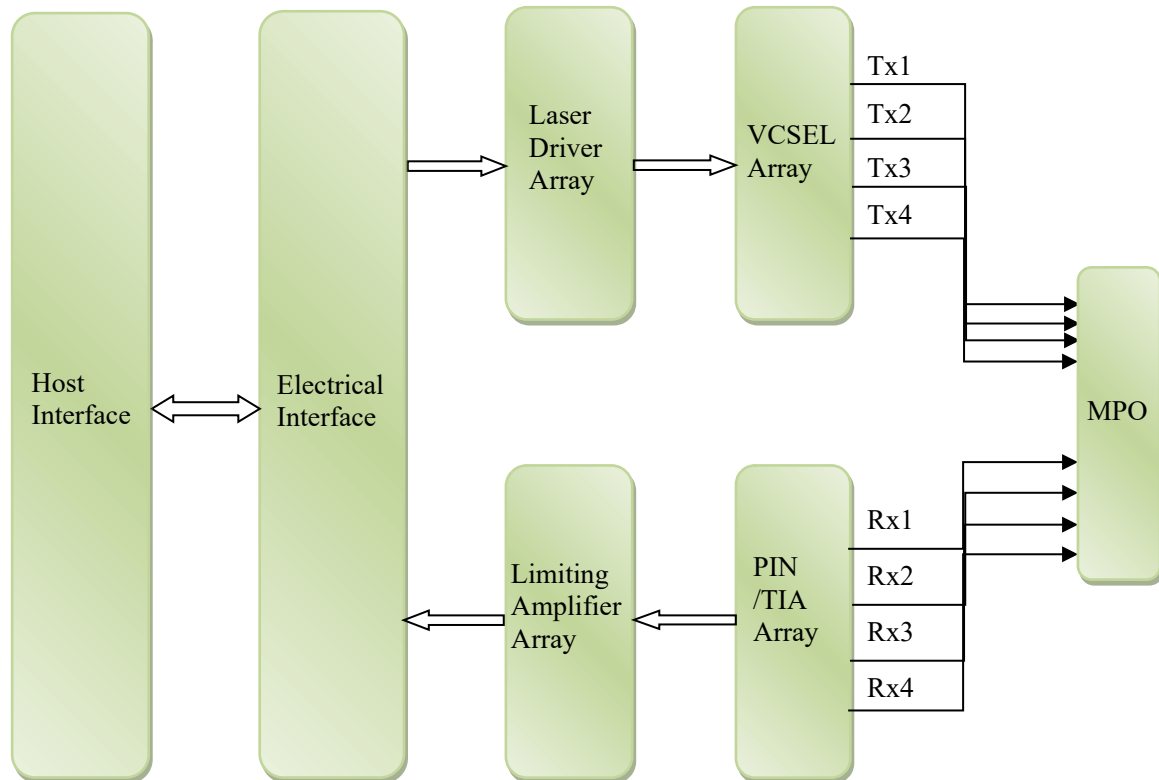

QSFP+ Transceiver Electrical Pad Layout

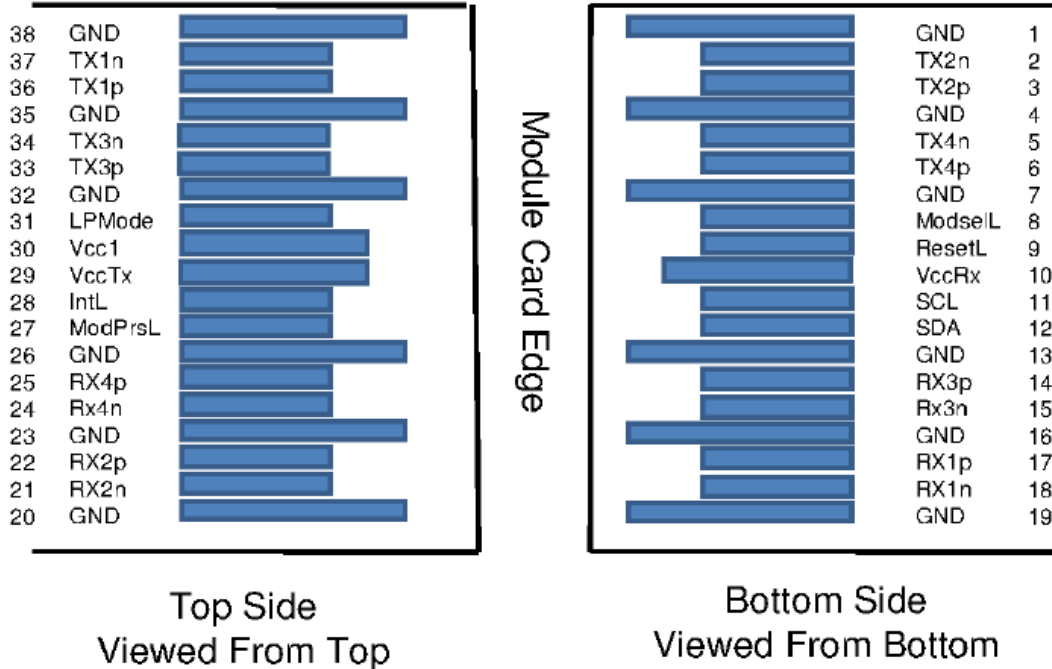

Pin Arrangement and Definition

Pin	Logic	Symbol	Description	Plug Sequence	Notes
1		GND	Ground	1	1
2	CML-I	Tx2n	Transmitter Inverted Data Input	3	
3	CML-I	Tx2p	Transmitter Non-Inverted Data Input	3	
4		GND	Ground	1	1
5	CML-I	Tx4n	Transmitter Inverted Data Input	3	
6	CML-I	Tx4p	Transmitter Non-Inverted Data Input	3	
7		GND	Ground	1	1
8	LVTTL-I	ModSelL	Module Select	3	
9	LVTTL-I	ResetL	Module Reset	3	
10		VccRx	+3.3V Power Supply Receiver	2	2
11	LVC MOS- I/O	SCL	2-wire serial interface clock	3	
12	LVC MOS- I/O	SDA	2-wire serial interface data	3	
13		GND	Ground	1	1
14	CML-O	Rx3p	Receiver Non-Inverted Data Output	3	
15	CML-O	Rx3n	Receiver Inverted Data Output	3	
16		GND	Ground	1	1
17	CML-O	Rx1p	Receiver Non-Inverted Data Output	3	
18	CML-O	Rx1n	Receiver Inverted Data Output	3	
19		GND	Ground	1	1
20		GND	Ground	1	1

21	CML-O	Rx2n	Receiver Inverted Data Output	3	
22	CML-O	Rx2p	Receiver Non-Inverted Data Output	3	
23		GND	Ground	1	1
24	CML-O	Rx4n	Receiver Inverted Data Output	3	
25	CML-O	Rx4p	Receiver Non-Inverted Data Output	3	
26		GND	Ground	1	1
27	LVTTL-O	ModPrsL	Module Present	3	
28	LVTTL-O	IntL	Interrupt	3	
29		VccTx	+3.3V Power supply transmitter	2	2
30		Vcc1	+3.3V Power supply	2	2
31	LVTTL-I	LPMode	Low Power Mode	3	
32		GND	Ground	1	1
33	CML-I	Tx3p	Transmitter Non-Inverted Data Input	3	
34	CML-I	Tx3n	Transmitter Inverted Data Input	3	
35		GND	Ground	1	1
36	CML-I	Tx1p	Transmitter Non-Inverted Data Input	3	
37	CML-I	Tx1n	Transmitter Inverted Data Input	3	
38		GND	Ground	1	1

1: GND is the symbol for signal and supply (power) common for the QSFP+ module. All are common within the QSFP+ module and all module voltages are referenced to this potential unless otherwise noted. Connect these directly to the host board signal-common ground plane.

2: Vcc Rx, Vcc1 and Vcc Tx are the receiver and transmitter power supplies and shall be applied concurrently. Requirements defined for the host side of the Host Edge Card Connector are listed in Table 6. Recommended host board power supply filtering is shown in Figures 3 and 4. Vcc Rx Vcc1 and Vcc Tx may be internally connected within the QSFP+ Module in any combination. The connector pins are each rated for a maximum current of 500mA.

Mechanical Specifications

