

**Single-Mode 40GBASE-ER4 QSFP+ Transceiver**

**Особенности:**

- до 40км на одномодовом оптическом кабеле
- четыре 10Gbps DFB CWDM канала в диапазоне 1300нм
- MDIO interface with integrated Digital Diagnostic Monitoring
- два стандартных LC оптических коннектора
- рабочая температура 0°C~+70°C

**Области применения:**

- 40GBASE-ER4 Ethernet links
- InfiniBand QDR and DDR interconnects Client-side
- 40G Telecom connections

Part No.	Data Rate	Fiber	Distance <sup>*(note1)</sup>	Interface	Temp.	DDMI
QSFP-Plus-ER4	40Gbps	SMF	40km	LC	-0°C~+70°C	Yes

Note1: Over SMF

**Absolute Maximum Ratings**

Parameter	Symbol	Min.	Max.	Unit
Storage Temperature	Ts	-40	+85	°C
Supply Voltage	Vcc	-0.5	3.6	V
Operating Relative Humidity	RH	5	85	%

\*Exceeding any one of these values may destroy the device immediately.

**Recommended Operating Conditions**

Parameter	Symbol	Min.	Typical	Max.	Unit
Operating Case Temperature	T <sub>A</sub>   QSFP-Plus-ER4	0		+70	°C
Power Supply Voltage	Vcc	3.15	3.3	3.45	V
Power Dissipation	P <sub>D</sub>			5	W
Link Distance with G.652	D		40		km

**Performance Specifications – Electrical**

Parameter	Symbol	Min.	Typ.	Max	Unit	Notes
Supply voltage		3.1		3.47	V	
Supply Current	I <sub>cc</sub>			1.44	A	
Transmit turn-on time				2000	ms	Note3
Differential Input Voltage Swing	V <sub>in,pp</sub>	190		700	mV <sub>p-p</sub>	
Input Impedance (Differential)	Z <sub>in</sub>	90	100	110	ohms	R <sub>in</sub> > 100 kohms @ DC
Differential output Voltage Swing	V <sub>out,pp</sub>	300		850	mV <sub>p-p</sub>	
AC common mode output voltage				7.5	mV	RMS
Output Impedance (Differential)	Z <sub>out</sub>	90	100	110	ohms	
Output Transition Time		28			ps	20%~80%

Note3: From power on and end of any fault conditions.

**Optical Characteristics**

Parameter	Symbol	Min.	Typical	Max.	Unit
Signaling Speed per Lane	BR <sub>AVE</sub>		10.3125	11.2	Gbps
Side Mode Launch Power	SMSR	30			dB
Total average launch power	P <sub>T</sub>			10.5	dBm
Lane_0 Center Wavelength	λ <sub>C0</sub>	1264.5	1271	1277.5	nm
Lane_1 Center Wavelength	λ <sub>C1</sub>	1284.5	1291	1297.5	nm
Lane_2 Center Wavelength	λ <sub>C2</sub>	1304.5	1311	1317.5	nm

Lane_3 Center Wavelength	$\lambda_{C3}$	1324.5	1331	1337.5	nm
Average Launch Power per Lane <sup>*(Note4)</sup>	Peach	-2.7		4.5	dBm
Average launch power of OFF transmitter per lane				-30	dBm
Relative Intensity Noise	R <sub>in</sub>			-128	dB/Hz
Optical modulation amplitude <sup>*(Note5)</sup>	P <sub>oma</sub>	0.3	0	5.0	dBm
Optical Return Loss Tolerance				20	dB
Difference in Launch Power between any two lanes	P <sub>tx,diff</sub>			4.7	dB
Transmitter Reflectance	RT			-12	dB
Extinction Ratio <sup>*(Note6)</sup>	ER	5.5			dB
Transmitter eye mask definition{X1, X2, X3, Y1, Y2, Y3} <sup>*(Not6)</sup>		{0.25, 0.4, 0.45, 0.25, 0.28, 0.4}			
Signaling Speed per Lane	BR <sub>AVE</sub>		10.3125		Gbps
Data Rate Variation		-100		+100	ppm
Damage threshold <sup>*(Not7)</sup>	R <sub>dam</sub>	3.8			dBm
Lane_0 Center Wavelength	$\lambda_{C0}$	1264.5	1271	1277.5	nm
Lane_1 Center Wavelength	$\lambda_{C1}$	1284.5	1291	1297.5	nm
Lane_2 Center Wavelength	$\lambda_{C2}$	1304.5	1311	1317.5	nm
Lane_3 Center Wavelength	$\lambda_{C3}$	1324.5	1331	1337.5	nm
Average Receive Power per Lane	R <sub>pow</sub>	-21.2		-4.5	dBm
Receiver Sensitivity in OMA per Lane <sup>*(Note8)</sup>	P <sub>min</sub>			-19	dBm

Stressed Receiver Sensitivity (OMA) per Lane <sup>*(Note9)</sup>	RX <sub>SRS</sub>			-16.8	dBm
Conditions of stressed receiver sensitivity test:					
Vertical Eye Closure Penalty <sup>*(Note10)</sup>	VECP		2.2		dB
Stressed J2 Jitter <sup>*(Note10)</sup>	J2		0.3		UI
Stressed J9 Jitter <sup>*(Note10)</sup>	J9		0.47		UI
LOS Assert	LOSA	TBD			dBm
LOS De-Assert	LOSD			-23	dBm
LOS Hysteresis		0.5			dB

Note4: Average launch power, each lane (min) is informative and not the principal indicator of signal strength. A transmitter with launch power below this value cannot be compliant; however, a value above this does not ensure compliance.

Note5: Even if the TDP < 0.8dB, the OMA (min) must exceed this value. Note6: Filtered, measured with a PRBS 231-1 test pattern @10.3Gbps.

Note7: The receiver shall be able to tolerate, without damage, continuous exposure to an optical input signal having this average power level.

Note8: Minimum average optical power measured at BER less than 1E-12, with a 231-1 PRBS. Note9: Measured with conformance test signal at TP3 for BER=1E-12.

Note10: Vertical eye closure penalty, stressed eye J2 Jitter, stressed eye J9 Jitter are test conditions for measuring stressed receiver sensitivity. They are not characteristics of the receiver.

## Functional Description of Transceiver

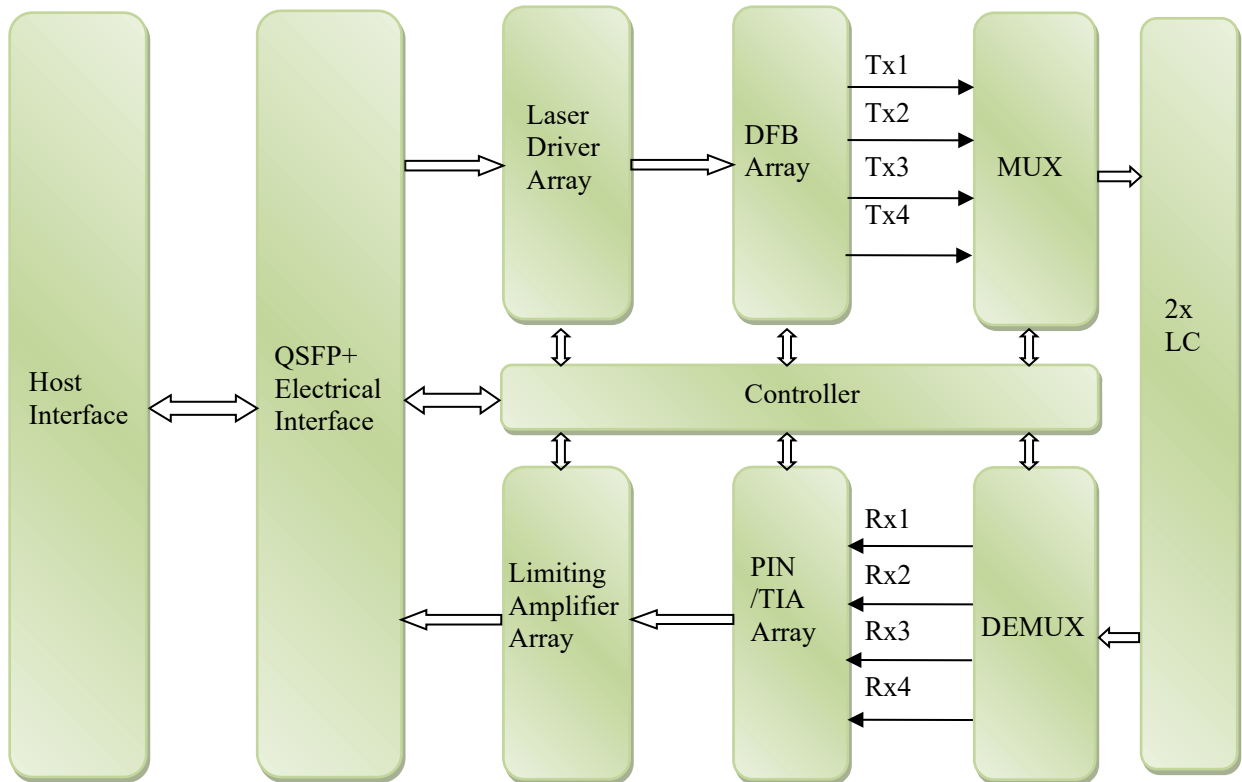

**QSFP+ Transceiver Electrical Pad Layout**

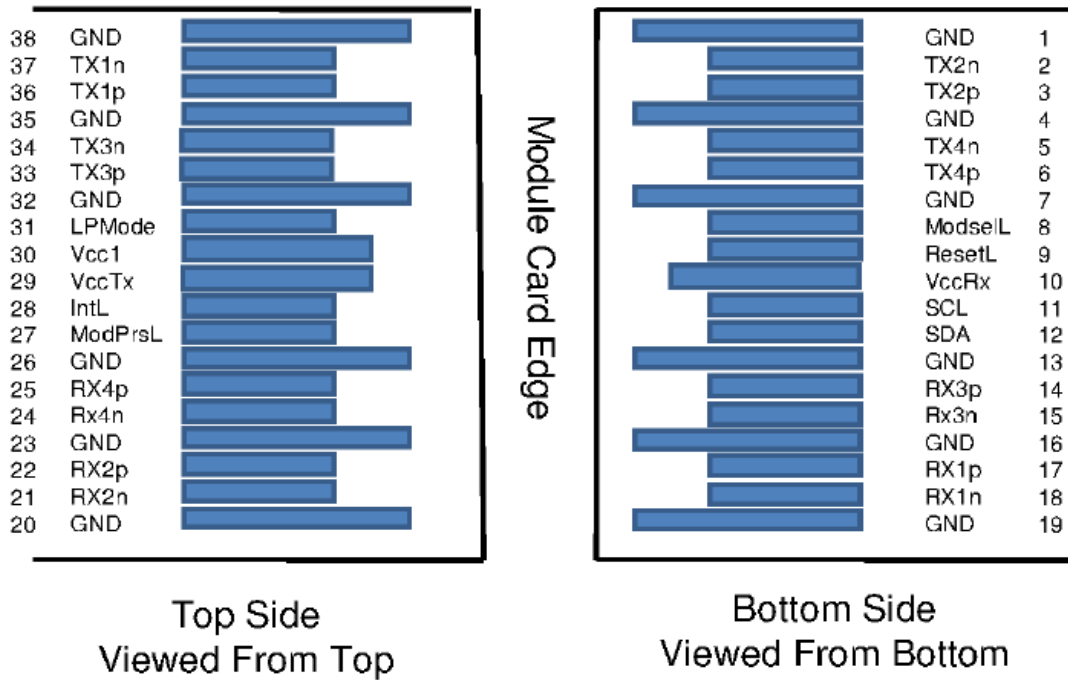

**Pin Arrangement and Definition**

Pin	Logic	Symbol	Description	Plug Sequence	Notes
1		GND	Ground	1	1
2	CML-I	Tx2n	Transmitter Inverted Data Input	3	
3	CML-I	Tx2p	Transmitter Non-Inverted Data Input	3	
4		GND	Ground	1	1
5	CML-I	Tx4n	Transmitter Inverted Data Input	3	
6	CML-I	Tx4p	Transmitter Non-Inverted Data Input	3	
7		GND	Ground	1	1
8	LVTTL-I	ModSelL	Module Select	3	
9	LVTTL-I	ResetL	Module Reset	3	
10		VccRx	+3.3V Power Supply Receiver	2	2
11	LVC MOS- I/O	SCL	2-wire serial interface clock	3	
12	LVC MOS- I/O	SDA	2-wire serial interface data	3	
13		GND	Ground	1	1
14	CML-O	Rx3p	Receiver Non-Inverted Data Output	3	
15	CML-O	Rx3n	Receiver Inverted Data Output	3	
16		GND	Ground	1	1
17	CML-O	Rx1p	Receiver Non-Inverted Data Output	3	
18	CML-O	Rx1n	Receiver Inverted Data Output	3	
19		GND	Ground	1	1
20		GND	Ground	1	1
21	CML-O	Rx2n	Receiver Inverted Data Output	3	

22	CML-O	Rx2p	Receiver Non-Inverted Data Output	3	
23		GND	Ground	1	1
24	CML-O	Rx4n	Receiver Inverted Data Output	3	
25	CML-O	Rx4p	Receiver Non-Inverted Data Output	3	
26		GND	Ground	1	1
27	LVTTL-O	ModPrsL	Module Present	3	
28	LVTTL-O	IntL	Interrupt	3	
29		VccTx	+3.3V Power supply transmitter	2	2
30		Vcc1	+3.3V Power supply	2	2
31	LVTTL-I	LPMode	Low Power Mode	3	
32		GND	Ground	1	1
33	CML-I	Tx3p	Transmitter Non-Inverted Data Input	3	
34	CML-I	Tx3n	Transmitter Inverted Data Input	3	
35		GND	Ground	1	1
36	CML-I	Tx1p	Transmitter Non-Inverted Data Input	3	
37	CML-I	Tx1n	Transmitter Inverted Data Input	3	
38		GND	Ground	1	1

1: GND is the symbol for signal and supply (power) common for the QSFP+ module. All are common within the QSFP+ module and all module voltages are referenced to this potential unless otherwise noted. Connect these directly to the host board signal-common ground plane.

2: Vcc Rx, Vcc1 and Vcc Tx are the receiver and transmitter power supplies and shall be applied concurrently. Requirements defined for the host side of the Host Edge Card Connector are listed in Table 6. Recommended host board power supply filtering is shown in Figures 3 and 4. Vcc Rx Vcc1 and Vcc Tx may be internally connected within the QSFP+ Module in any combination. The connector pins are each rated for a maximum current of 500mA.

**Mechanical Specifications**

# QSFP-Plus-ER4

*Optiset*

