

## Модуль 10G SFP+, SM, 1310nm, 15km, Industrial -40 +85°C, LC

## Особенности:

- скорость передачи: 10 Гбит/с
- рабочая температура: -40...+85°C
- дальность передачи: 15км
- функция диагностики (DDMI) в соответствии с SFF-8472
- длина волны передатчика Tx: 1310nm
- тип лазера: DFB-LD
- длина волны Rx: 1270-1355 nm
- мощность передатчика Tx: -4... +1 dBm
- чувствительность приемника Rx: -14 dBm

## Области применения:

- 10GBASE-LR at 10.31Gbps, 10GBASE-LW at 9.95Gbps;
- CPRI rates 10.138Gb/s ,9.830 Gb/s,7.373Gb/s, 6.144 Gb/s, 4.915Gb/s, 2.458 Gb/s, 1.229 Gb/s, 0.614Gb/s

## Absolute Maximum Ratings

Parameter	Symbol	Min.	Max.	Unit
Storage Temperature	T <sub>s</sub>	-40	+85	°C
Supply Voltage	V <sub>CC</sub>	-0.5	3.6	V
Input Voltage	V <sub>in</sub>	-0.5	V <sub>CC</sub>	V
Output Current	I <sub>o</sub>	-	50	mA

## Recommended Operating Conditions

Parameter	Symbol	Min.	Typical	Max.	Unit
	SFP-Plus-LR.15-I	-40		+85	
Power Supply Voltage	V <sub>CC</sub>	3.15	3.3	3.45	V
Power Supply Current	I <sub>CC</sub>			430	mA
Surge Current	I <sub>Surge</sub>			+30	mA
Baud Rate	10GBASE-LR		10.31		Gbps

## Performance Specifications – Electrical

Parameter	Symbol	Min.	Typ.	Max	Unit	Notes
<b>Transmitter</b>						
CML Inputs(Differential)	V <sub>in</sub>	150		1200	mVpp	AC coupled inputs
Input AC Common Mode Voltage		0		25	mV	RMS
Input Impedance (Differential)	Z <sub>in</sub>	85	100	115	ohm	R <sub>in</sub> > 100 kohms @ DC

Differential Input S-parameter	S <sub>DD11</sub>	-	-	-10	dB	
Differential to Common Mode Conversion	S <sub>CD11</sub>	-	-	-10	dB	
Tx_DISABLE Input Voltage – High		2		3.45	V	
Tx_DISABLE Input Voltage – Low		0		0.8	V	
Tx_FAULT Output Voltage – High		2		V <sub>cc</sub> +0.3	V	I <sub>o</sub> = 400µA; Host V <sub>cc</sub>
Tx_FAULT Output Voltage – Low		0		0.5	V	I <sub>o</sub> = -4.0mA
<b>Receiver</b>						
CML Outputs (Differential)	V <sub>out</sub>	350		700	mVpp	AC coupled outputs
Output AC Common Mode Voltage		0		15	mV	RMS
Output Impedance (Differential)	Z <sub>out</sub>	90	100	110	ohm	
Differential Output S-parameter	S <sub>D22</sub>	-	-	-10	dB	
Rx_LOS Output Voltage – High		2		V <sub>cc</sub> +0.3	V	I <sub>o</sub> = 400µA; Host V <sub>cc</sub>
Rx_LOS Output Voltage – Low		0		0.8	V	I <sub>o</sub> = -4.0mA
MOD_DEF ( 0:2 )	VoH	2.5			V	With Serial ID
	VoL	0		0.5	V	

**Performance Specifications – Optical**

Parameter	Symbol	Min.	Typical	Max.	Unit
9µm Core Diameter SMF			15		Km
Data Rate				10.3	Gbps
<b>Transmitter</b>					
Centre Wavelength	λ <sub>c</sub>	1270	1310	1355	nm
Spectral Width (-20dB)	Δλ			1	nm
Average Output Power	P <sub>out</sub>	-4		+1	dBm
Extinction Ratio	ER	3.5			dB
Average Power of OFF Transmitter	P <sub>off</sub>			-30	dBm
Side Mode Suppression Ratio	SMSR	30			dB
Transmitter Dispersion Penalty	TDP			2	dB
Input Differential Impedance	Z <sub>IN</sub>	90	100	110	Ω
TX Disable	Disable		2.0	V <sub>cc</sub> +0.3	V
	Enable		0	0.8	
TX Fault	Fault		2.0	V <sub>cc</sub> +0.3	V
	Normal		0	0.8	
TX Disable Assert Time	t <sub>off</sub>	-	-	10	us
TX_DISABLE Negate Time	t <sub>on</sub>	-	-	1	ms
TX_BISABLE time to start reset	t <sub>reset</sub>	10	-	-	us

Time to initialize, include reset of TX_FAULT	t_init	-	-	300	ms
TX_FAULT from fault to assertion	t_fault	-	-	100	us
Total Jitter	TJ	-	-	0.28	UI(p-p)
Data Dependant Jitter	DDJ	-	-	0.1	UI(p-p)
Uncorrelated Jitter	UJ	-	-	0.023	RMS
<b>Receiver</b>					
Centre Wavelength	$\lambda$	1260		1565	nm
Sensitivity	P <sub>min</sub>			-14	dBm
Receiver Overload	P <sub>max</sub>	0.5			dBm
Optical Return Loss	ORL			-12	dB
LOS De-Assert	LOS <sub>D</sub>			-15	dBm
LOS Assert	LOS <sub>A</sub>	-25			dBm
LOS	High		2.0	V <sub>CC</sub> +0.3	V
	Low		0	0.8	

SFP+ Transceiver Electrical Pad Layout

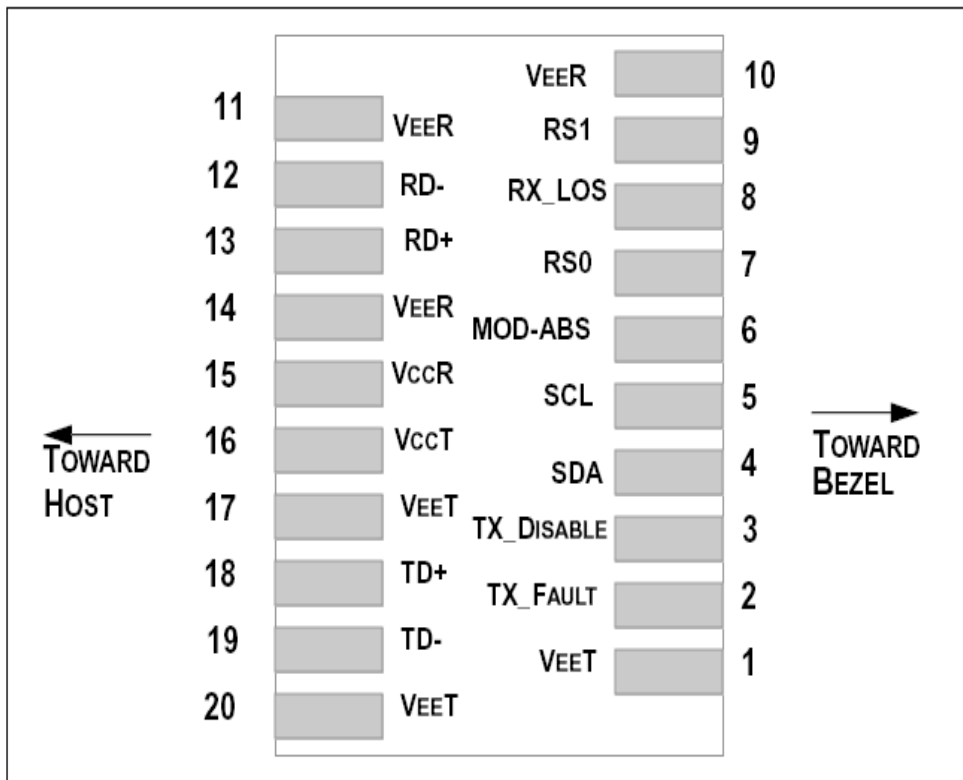

## Pin Function Definitions

Pin Num.	Name	FUNCTION	Plug	Notes
1	VeeT	Transmitter Ground	1	Note 5
2	TX Fault	Transmitter Fault Indication	3	Note 1
3	TX Disable	Transmitter Disable	3	Note 2, Module disables on high or open
4	SDA	Module Definition 2	3	Data line for Serial ID.
5	SCL	Module Definition 1	3	Clock line for Serial ID.
6	MOD-ABS	Module Definition 0	3	Note 3
7	RS0	RX Rate Select (LVTTTL).	3	This pin has an internal 30k pull down to ground. A signal on this pin will not affect module performance.
8	LOS	Loss of Signal	3	Note 4
9	RS1	TX Rate Select (LVTTTL).	1	This pin has an internal 30k pull down to ground. A signal on this pin will not affect module performance.
10	VeeR	Receiver Ground	1	Note 5
11	VeeR	Receiver Ground	1	Note 5
12	RD-	Inv. Received Data Out	3	Note 6
13	RD+	Received Data Out	3	Note 7
14	VeeR	Receiver Ground	1	Note 5
15	VccR	Receiver Power	2	3.3V $\pm$ 5%, Note 7
16	VccT	Transmitter Power	2	3.3V $\pm$ 5%, Note 7
17	VeeT	Transmitter Ground	1	Note 5
18	TD+	Transmit Data In	3	Note 8
19	TD-	Inv. Transmit Data In	3	Note 8
20	VeeT	Transmitter Ground	1	Note 5

## Notes:

1) TX Fault is an open collector/drain output, which should be pulled up with a 4.7K – 10K $\Omega$  resistor on the host board. Pull up voltage between 2.0V and VccT/R+0.3V. When high, output indicates a laser fault of some kind. Low indicates normal operation. In the low state, the output will be pulled to < 0.8V.

2) TX disable is an input that is used to shut down the transmitter optical output. It is pulled up within the module with a 4.7K – 10 K $\Omega$  resistor. Its states are:

Low (0 – 0.8V): Transmitter on

(>0.8, < 2.0V): Undefined

High (2.0 – 3.465V): Transmitter Disabled

Open: Transmitter Disabled

3) Modulation Absent, connected to VeeT or VeeR in the module.

4) LOS (Loss of Signal) is an open collector/drain output, which should be pulled up with a 4.7K – 10K $\Omega$  resistor. Pull up voltage between 2.0V and VccT/R+0.3V. When high, this output indicates the received optical power is below the worst-case receiver sensitivity

(as defined by the standard in use). Low indicates normal operation. In the low state, the output will be pulled to < 0.8V.

5) VeeR and VeeT may be internally connected within the SFP+ module.

6) RD-/+ : These are the differential receiver outputs. They are AC coupled 100Ω differential lines which should be terminated with 100Ω (differential) at the user SERDES. The AC coupling is done inside the module and is thus not required on the host board.

7) VccR and VccT are the receiver and transmitter power supplies. They are defined as 3.3V ±5% at the SFP+ connector pin. Maximum supply current is 300mA. Inductors with DC resistance of less than 1 ohm should be used in order to maintain the required voltage at the SFP+ input pin with 3.3V supply voltage. When the recommended supply-filtering network is used, hot plugging of the SFP+ transceiver module will result in an inrush current of no more than 30mA greater than the steady state value. VccR and VccT may be internally connected within the SFP+ transceiver module.

8) TD-/+ : These are the differential transmitter inputs. They are AC-coupled, differential lines with 100Ω differential termination inside the module. The AC coupling is done inside the module and is thus not required on the host board.

## EEPROM

The serial interface uses the 2-wire serial CMOS EEPROM protocol defined for the ATMEL AT24C02/04 family of components. When the serial protocol is activated, the host generates the serial clock signal (SCL). The positive edge clocks data into those segments of the EEPROM that are not written protected within the SFP+ transceiver. The negative edge clocks data from the SFP+ transceiver. The serial data signal (SDA) is bi-directional for serial data transfer. The host uses SDA in conjunction with SCL to mark the start and end of serial protocol activation. The memories are organized as a series of 8-bit data words that can be addressed individually or sequentially.

The Module provides diagnostic information about the present operating conditions. The transceiver generates this diagnostic data by digitization of internal analog signals. Calibration and alarm/warning threshold data is written during device manufacture. Received power monitoring, transmitted power monitoring, bias current monitoring, supply voltage monitoring and temperature monitoring all are implemented. If the module is defined as external calibrated, the diagnostic data are raw A/D values and must be converted to real world units using calibration constants stored in EEPROM locations 56 – 95 at wire serial bus address A2h. The digital diagnostic memory map specific data field define as following .For detail EEPROM information, please refer to the related document of SFF 8472 Rev 10.2.

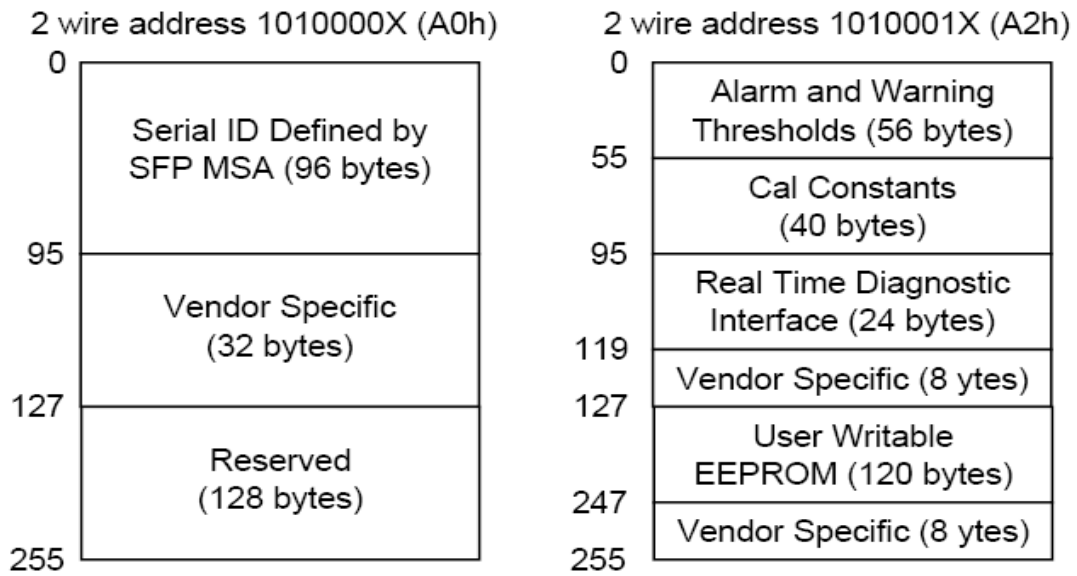

Recommend Circuit Schematic

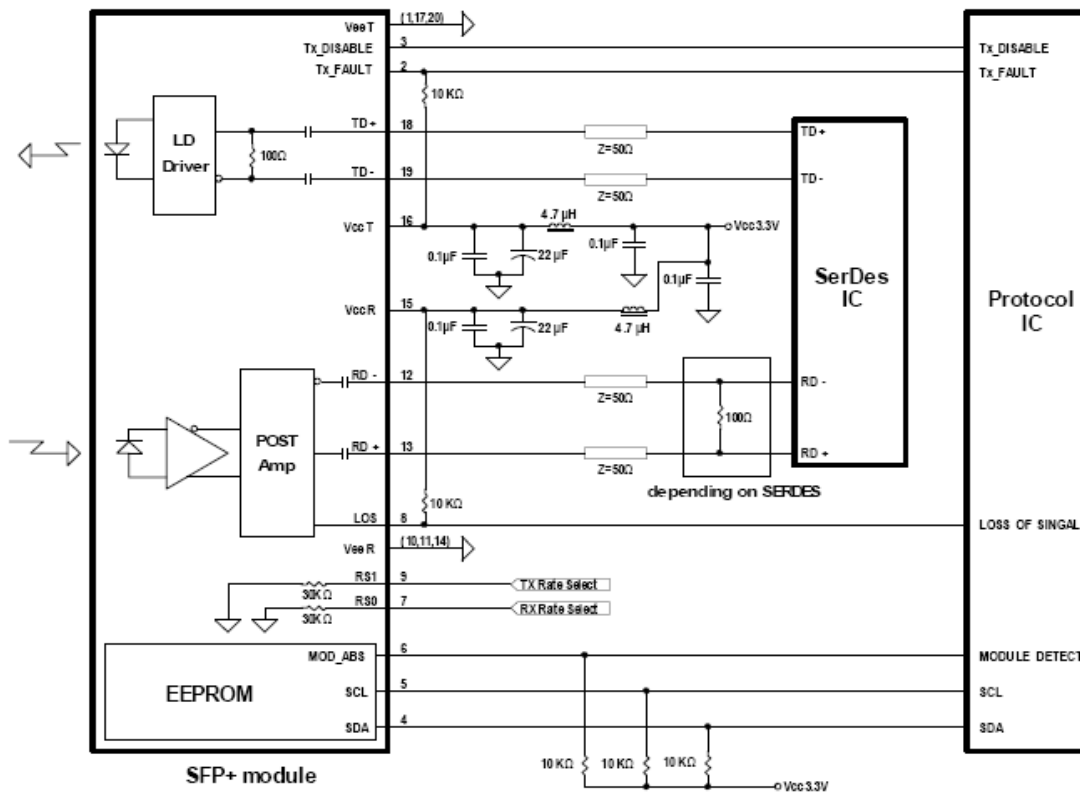

Mechanical Specifications

